



MEGADYNE



***ENERGY:
NATURAL GAS
& OIL FIELD***

AM-EN

INDUSTRY
BROCHURE



ENERGY: NATURAL GAS & OIL FIELD

We offer products and accessory items supporting the oil and gas industry in applications from drilling and extraction to transport and delivery. Our belts ensure efficient and reliable operations, including power transmission and moving products. In this brochure, you will find the overview of the key processes and auxiliary equipment from land-based to offshore oil exploration where our belting solutions prove their worth.

Megadyne has been catering to your needs since 1957, designing and manufacturing power transmission belts, matched components, and complete belt systems for all types of equipment. We are a reliable partner for original equipment manufacturers and aftermarket distributors, with:

9 manufacturing plants in Europe, North America, and Asia, more than 170 Customer Solution Centres and 3 main distribution hubs around the world, able to deliver products efficiently, from large industrial sites to remote locations.

BELT PROPERTIES



MEGADYNE MEGASYNC™ (GOLD2, SILVER3)

SUPPLIED AS	Endless
LENGTH	248 - 4 956 mm
WIDTH	12 - 170 mm*
PITCH	H SLV3 8M, SLV3 14M, GLD2 8M, GLD2 14M
TENSION MEMBER	Fiberglass
FEATURES	High stability and resistance, antistatic

*Standard Width Range - Megadyne will cut to desired width upon request.



MEGADYNE MEGASYNC™ TITANIUM

SUPPLIED AS	Endless
LENGTH	248 - 4 956 mm
WIDTH	12 - 170 mm*
PITCH	TTM8, TTM14
TENSION MEMBER	Special Carbon Cord
FEATURES	Compact drive package, high stability and resistance

*Standard Width Range - Megadyne will cut to desired width upon request.



MEGADYNE V-BELTS

SUPPLIED AS	Endless - Wrapped - Raw edge
LENGTH	Consult MEGADYNE
WIDTH	According to section
PITCH	Wrapped B, C, D; Narrow 3V, 5V, 8V; Raw Edge BX, CX
TENSION MEMBER	Polyester
FEATURES	Long life and good performance



MEGADYNE V-BELTS - PLURIBAND	
SUPPLIED AS	Endless
LENGTH	2 540 - 15 250 mm
WIDTH	According to the number of V-belts
PITCH	R8V
TENSION MEMBER	Polyester
FEATURES	Oil and heat resistant, static dissipating

METAL DRIVE COMPONENTS

Use an extensive range of pulleys and accessories like timing bars, flanges, clamping plates, couplings to design a complete drive transmission system.



CERTIFICATIONS



All Megadyne polyurethane power transmission belts comply with ISO 14001, ISO 9001 and European RoHS Directive. The belts are made with raw materials in compliance with REACH standards, meaning that all belts, pulleys, toothed bars, couplings blocking units and other items supplied by Megadyne do not contain one (or several) of the SVHC in Candidate List above a concentration of 0.1% w/w.

All Megadyne rubber power transmission belts are made in accordance with the Quality Management System Standard: ISO 9001:2015 and ISO 14001:2015. These certificates are valid for the following field of application: design, manufacture and sale of power transmission belts. Marketing of transmission and transport elements (pulleys, tensiometers).

DRILLING: MUD PUMPS

Mud pumps (drilling fluid pumps) deliver fluids under high pressure underground to remove the rock cuttings from the bottom of the drill bit/hole as the drill continues its downward pursuit to the oil reservoir. Other fluids delivered from the pump are used to mitigate residue from the drill bit and also help the bit to stay cool. This fluid is then pumped back to the surface where the liquid and rock pieces are then sent through a shale shaker. Mud pumps must handle high horsepower and use large belts.

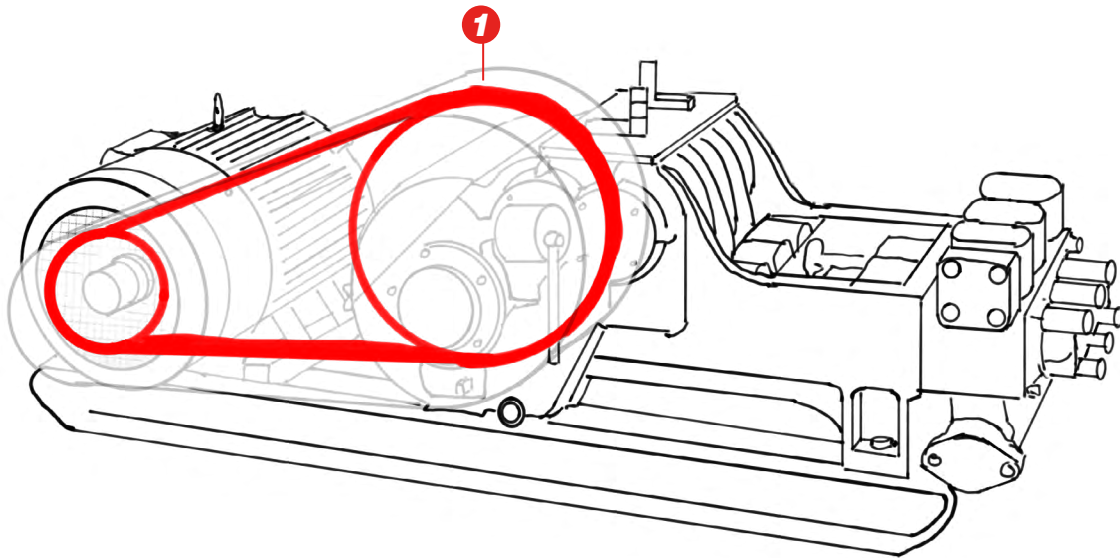

PLURIBAND

Banded version of V-belts for high loads applications (R8V).

- Oil resistant
- Antistatic



MEGASYNC™ TITANIUM

Top of the line rubber endless timing belts, with superior power and torque drives capacity, even in the most extreme operating conditions (TTM8 and TTM14).

- Compact drive package
- High stability and resistance
- Long life cycles, cost-efficiency

DRILLING: SHALE SHAKER

As drilling fluids and contaminants are pumped back out of the drilling area, material is passed through a shaker. The shaker is made up of several screens that separate rock fragments from the water/mud.

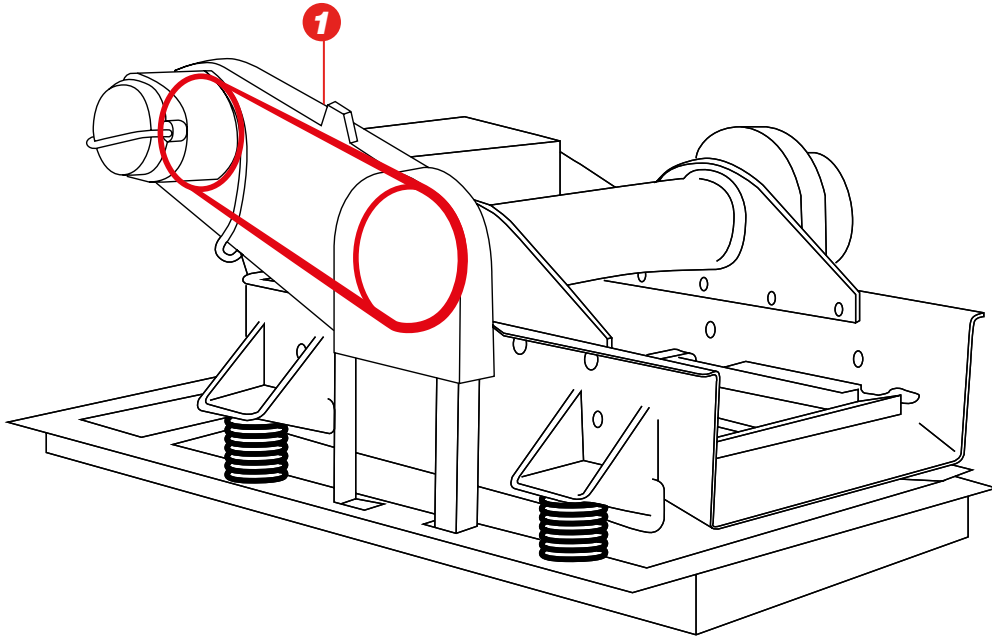

PLURIBAND

Banded version of V-belts for high loads applications (R8V).

- Oil resistant
- Antistatic



V-BELT

Wrapped V-belts, made of polybutadiene compound in a wide variety of sizes and sections (B, C, D, 3V, 5V, 8V).

- Oil and heat resistant
- Long and reliable service life
- Reduced operational cost

DRILLING: SHEAR PUMPS

Shear pumps are belt-driven units used to mix various fluids into the mud that is fed back into the drilling pipe in order to improve drilling efficiency.

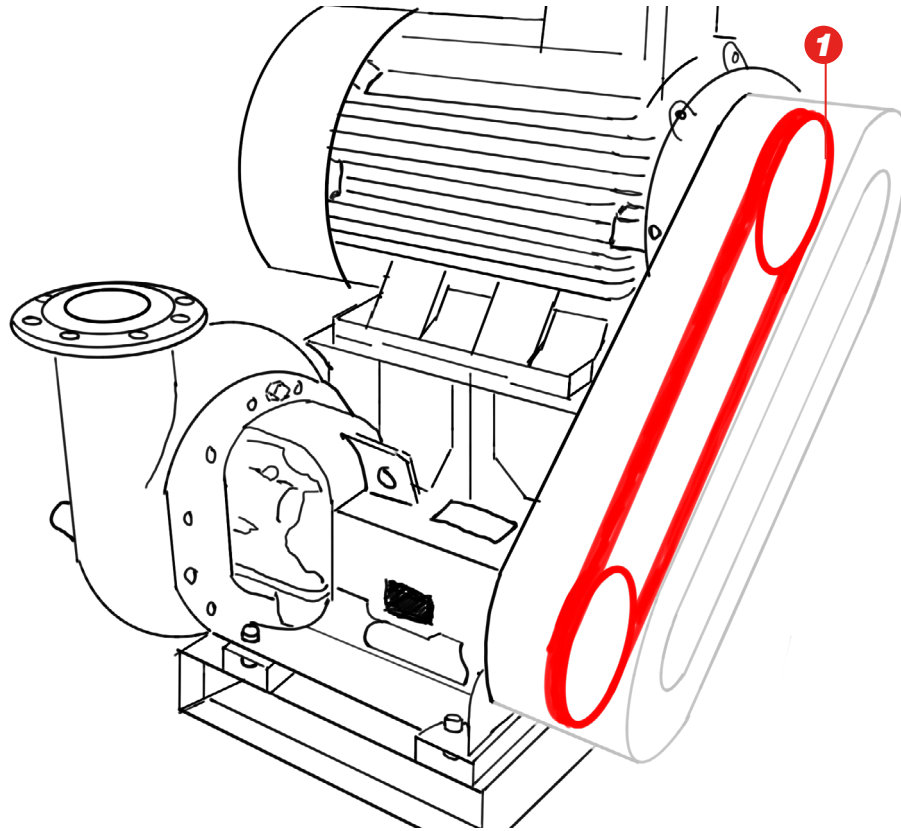

V-BELT

Wrapped V-belts, made of polybutadiene compound in a wide variety of sizes and sections (B, C, D, 3V, 5V, 8V).

- Oil and heat resistant
- Long and reliable service life
- Reduced operational cost



DYNAMIC-X

The new generation of raw edge V-belts with narrow cross-section and raw edge construction, based on a new EPDM rubber compound (BX, CX sections).

- Resistant to chemically aggressive environments, ageing, ozone, UV and heat



MEGASYN™ TITANIUM

Top of the line rubber endless timing belts, with superior power and torque drives capacity, even in the most extreme operating conditions (TTM8 and TTM14).

- Compact drive package
- High stability and resistance
- Long life cycles, cost-efficiency

EXTRACTION: WELLHEAD COMPRESSOR

Wellhead compressors are used to relieve pressure in order to create an efficient flow of oil to the surface and to the holding tank. Wellhead compressors are mainly used when the oil production is beginning to end and where oil still remains in the reservoir. In addition to helping improve the oil flow to the surface, wellhead compressors also extend the life of the well. Wellhead compressors are also used when moving the oil from the holding tank to the oilfield pipeline and onto refining.

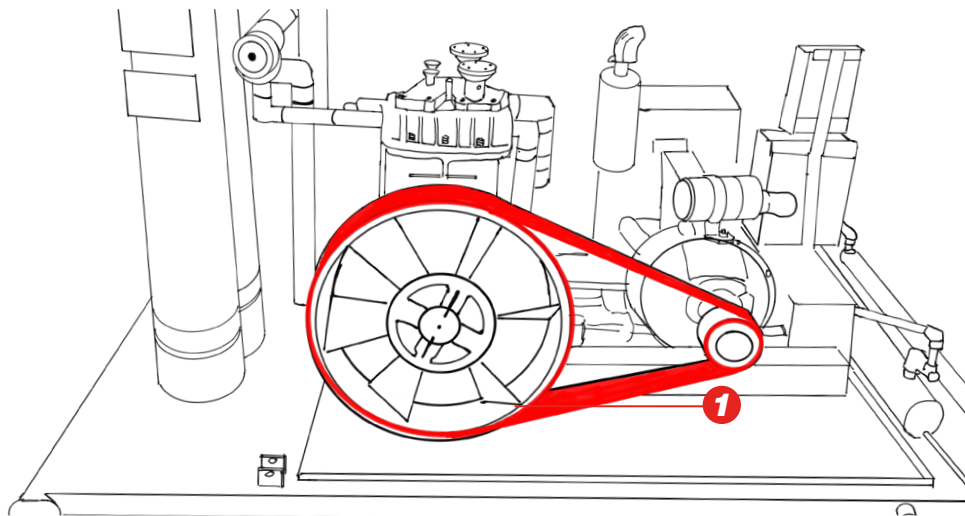

V-BELT

Wrapped V-belts, made of polybutadiene compound in a wide variety of sizes and sections (B, C, D, 3V, 5V, 8V).

- Oil and heat resistant
- Long and reliable service life
- Reduced operational cost



DYNAMIC-X

The new generation of raw edge V-belts with narrow cross-section and raw edge construction, based on a new EPDM rubber compound (BX, CX sections).

- Resistant to chemically aggressive environments, ageing, ozone, UV and heat



MEGASYNC™ TITANIUM

Top of the line rubber endless timing belts, with superior power and torque drives capacity, even in the most extreme operating conditions (TTM8 and TTM14).

- Compact drive package
- High stability and resistance
- Long life cycles, cost-efficiency

EXTRACTION: PUMPJACK

Once oil has been reached, the drilling rig is removed and replaced with a pumpjack. These units are used to mechanically lift fluid out of the well where not enough bottom hole pressure exists for the liquid to reach the surface.

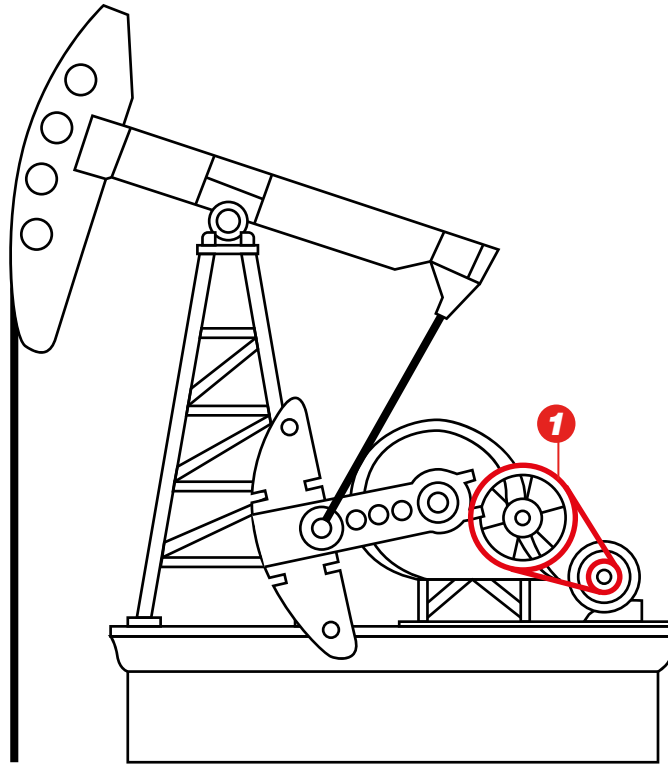

V-BELT

Wrapped V-belts, made of polybutadiene compound in a wide variety of sizes and sections (B, C, D, 3V, 5V, 8V).

- Oil and heat resistant
- Long and reliable service life
- Reduced operational cost



DYNAMIC-X

The new generation of raw edge V-belts with narrow cross-section and raw edge construction, based on a new EPDM rubber compound (BX, CX sections).

- Resistant to chemically aggressive environments, ageing, ozone, UV and heat

EXTRACTION: OFFSHORE PLUNGER PUMPS

In the case of oil platform exploration, salt water accompanies the oil to the surface. After separation from the oil, the saltwater is then pumped back into the oil reservoir using a plunger pump. This step helps in the continuing effort to build constant flow of the oil to the surface.

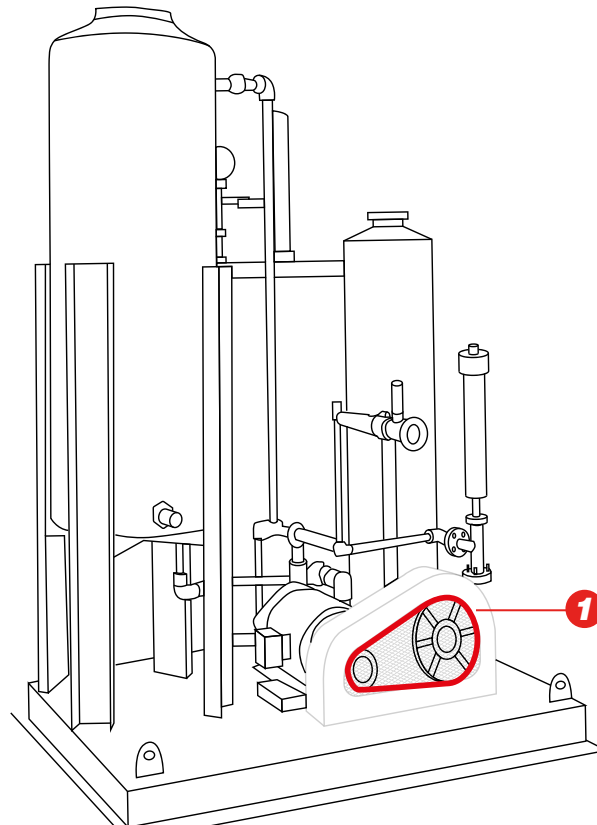

V-BELT

Wrapped V-belts, made of polybutadiene compound in a wide variety of sizes and sections (B, C, D, 3V, 5V, 8V).

- Oil and heat resistant
- Long and reliable service life
- Reduced operational cost



DYNAMIC-X

The new generation of raw edge V-belts with narrow cross-section and raw edge construction, based on a new EPDM rubber compound (BX, CX sections).

- Resistant to chemically aggressive environments, ageing, ozone, UV and heat



MEGASYNC™ TITANIUM

Top of the line rubber endless timing belts, with superior power and torque drives capacity, even in the most extreme operating conditions (TTM8 and TTM14).

- Compact drive package
- High stability and resistance
- Long life cycles, cost-efficiency

REFINING: AIR-COOLED HEAT EXCHANGER

Air Cooled Heat Exchangers (ACHE) are used in refineries or any application where hot liquids or gasses are being processed. It is a type of heat exchanger that forces air over a set of coils to cool the process.

Generally used where a process system generates heat which must be removed. They are also known as a Fin-Fan®.

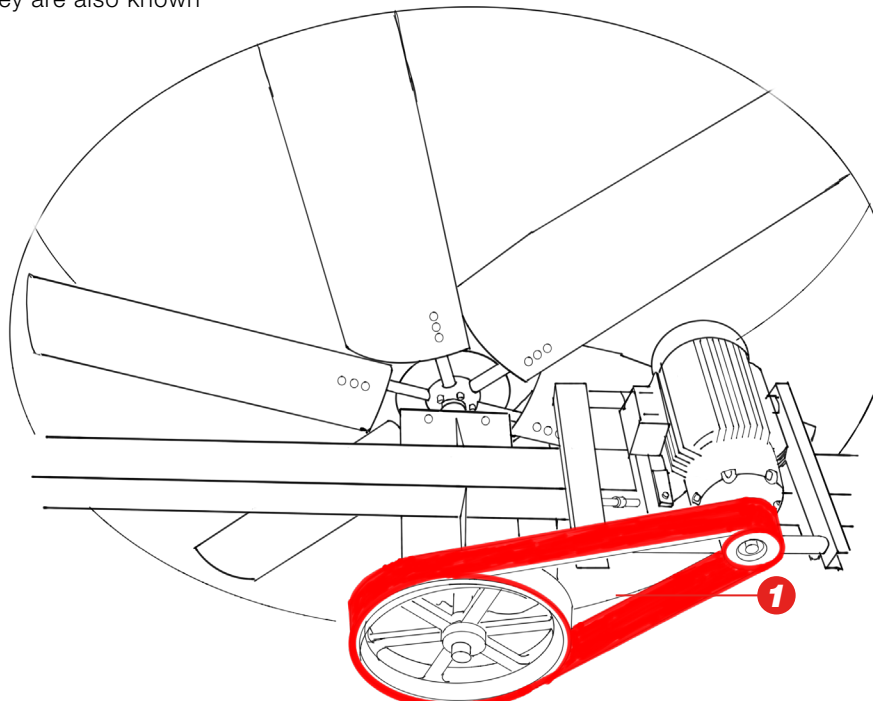

MEGADYNE MEGASYNC™ SILVER3

Rubber endless timing belts with spiral fiberglass cords and RPP profile (SLV3 8M, SLV3 14M).

- High-speed capacity
- High precision drives
- Antistatic



MEGADYNE MEGASYNC™ GOLD2

Rubber endless timing belts with spiral fiberglass cords and RPP profile (GLD2 8M, GLD2 14M).

- Low friction coefficient
- High transmission efficiency
- Long lasting
- Antistatic

STIMULATION FRACTURING PUMP

Stimulation fluid, which is a mixture of over 90% water and sand, plus a few chemical additives, is pumped under controlled conditions into deep, underground reservoir formations. The chemicals are used for lubrication, to keep bacteria from forming, to carry the sand, are typically non-hazardous and range in concentrations from 0.1% to 0.5% by volume. They are needed to help improve the performance and efficiency of the hydraulic fracturing. This process creates fractures in the shale rock which contains the oil and natural gas and aids in the extraction process.

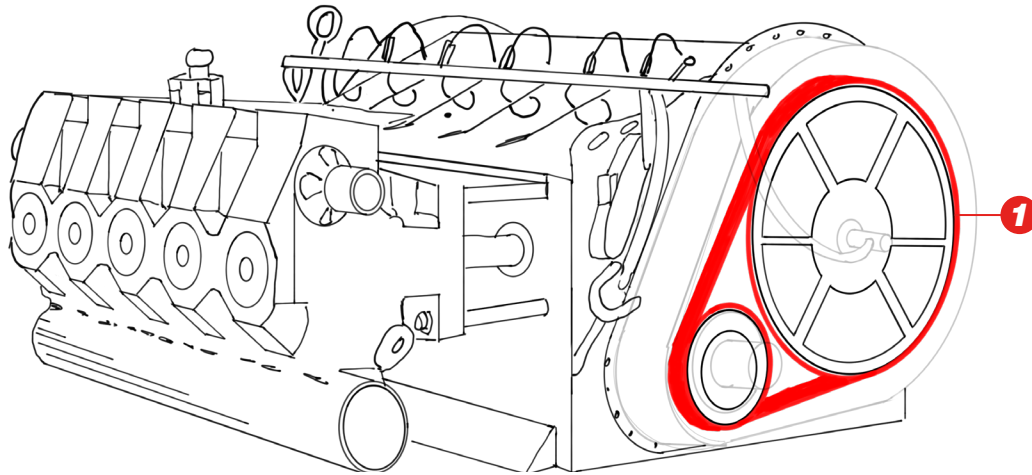

V-BELT

Wrapped V-belts, made of polybutadiene compound in a wide variety of sizes and sections (B, C, D, 3V, 5V, 8V).

- Oil and heat resistant
- Long and reliable service life
- Reduced operational cost



DYNAMIC-X

The new generation of raw edge V-belts with narrow cross-section and raw edge construction, based on a new EPDM rubber compound (BX, CX sections).

- Resistant to chemically aggressive environments, ageing, ozone, UV and heat



MEGASYNC™ TITANIUM

Top of the line rubber endless timing belts, with superior power and torque drives capacity, even in the most extreme operating conditions (TTM8 and TTM14).

- Compact drive package
- High stability and resistance
- Long life cycles, cost-efficiency

Discover Your Local Contacts

The local partner of choice
for sustainable power transmission belting solutions
around the globe.



Scan the QR code
and find your local
contact

General contact information:

Megadyne
5 Dedrick Place
West Caldwell, NJ 07006
United States

megadynegroup.com

