



MEGADYNE



ROLLER MILL BELTS

EN

INDUSTRY
BROCHURE

ROLLER MILL MACHINE

Roller mill machines are widely used in food-processing industries, for various applications such as grinding grains and barley to make bread, flour, and beer. These machines may also be used to produce a variety of powders and chemical products.

Megadyne Double Sided Roller Mill Belts are used in roller mills (food, corn, fruit, rice, flour, etc.) where the backside pulley has a reverse direction and relative slippage is necessary when the rolls are jammed.

Roller Mill Belts are available either Synchronous (8M, STD8 or 14M) on one side and Poly-V (PV-K or PV-L) on the other, double-sided synchronous or double-sided ribbed (PV-L). The ribbed profile allows functional slippage under jamming conditions and absorbs resulting torque spikes.

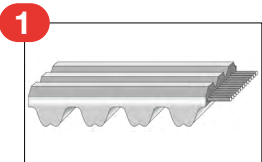
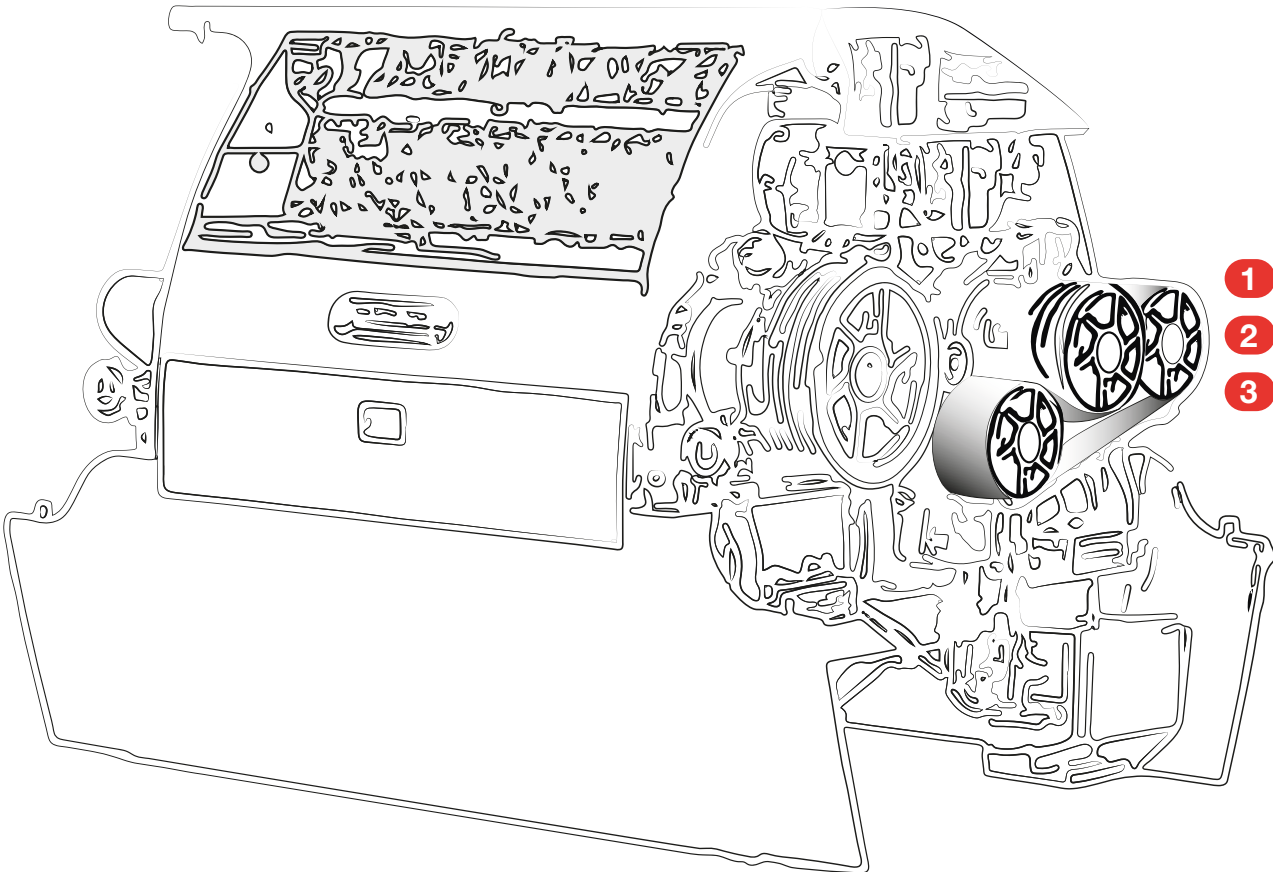

1 SYNCHRONOUS WITH PV BACK

The powerful solution.
When both slippage and power are required, this is the best solution. Synchronous side available in either RPP or STD profiles. Ribbed side available in either PV-K or PV-L profiles.

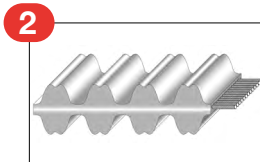

2 DOUBLE-SIDED SYNCHRONOUS

The standard solution.
A complete range of belts, available in either RPP or STD profiles. May be manufactured in different structures: standard, Silver or Gold.

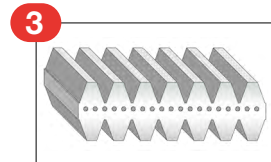

3 DOUBLE-SIDED POLY-V

The silent solution.
For applications where slippage is the name of the game and noise needs to be limited. Available in either PV-K or PV-L profiles.

BELTS SELECTION

SYNCHRONOUS WITH PV BACK

ITEM CODE	DESCRIPTION	WIDTH (ribs)	LENGTH (mm)	COMMONLY USED SETS
1760RPPV43	1760 RPP8 PK 12 PV BACK	12	1760	SET of 3
2000RPPV43	2000 RPP8 PK 12 PV BACK	12	2000	SET of 3
2400RPPV43	2400 RPP8 PK 12 PV BACK	12	2400	SET of 3
2400RPPV43	2400 RPP8 PK 12 PV BACK	12	2400	SET of 3
1552STD8PVK16SL	1552 STD8 PK 16 PV BACK SUPER	16	1552	SET of 2
1552STD8PVK30SL	1552 STD8 PK 30 PV BACK	30	1552	
1552STD8PVK32SL	1552 STD8 PK 32 PV BACK	32	1552	
1778RPP14PV43	1778 RPP14 PK 12 PV BACK	12	1778	SET of 3
1760PLUS8PVK12	1760 SLV8 PK 12 PV BACK PLUS	12	1760	SET of 3
1760PLUS8PVK16	1760 SLV8 PK 16 PV BACK PLUS	16	1760	SET of 2
1760PLUS8PVK28	1760 SLV8 PK 28 PV BACK PLUS	28	1760	
1760PLUS8PVK36	1760 SLV8 PK 36 PV BACK PLUS	36	1760	
1800PLUS8PVK16	1800 SLV8 PK 16 PV BACK PLUS	16	1800	
2000SLV8PVK12	2000 SLV8 PK 12 PV BACK	12	2000	SET of 3
2400PLUS8PVK12	2400 SLV8 PK 12 PV BACK PLUS	12	2400	SET of 2
2400PLUS8PVK36	2400 SLV8 PK 36 PV BACK PLUS	36	2400	
1610SLV14PVK24	1610 SLV14 PK 24 PV BACK	24	1610	
1610SLV14PVK36	1610 SLV14 PK 36 PV BACK	36	1610	
1764SLV14PVL12SCA	1764 SLV14 PL 12 PV BACK R0068	12	1764	SET of 2
1764SLV14PVK12	1764 SLV14 PK 12 PV BACK	12	1764	SET of 3
1778PLUS14PVK12	1778 SLV14 PK 12 PV BACK PLUS	12	1778	SET of 3
1890PLUS14PVK12	1890 SLV14 PK 12 PV BACK PLUS	12	1890	SET of 3
1890PLUS14PVK24	1890 SLV14 PK 24 PV BACK PLUS	24	1890	
1764PTH14PVK12	1764 GLD14 PK 12 PV BACK	12	1764	SET of 3
2400GLD8PVK12SCA	2400 GLD8 PK 12 PV BACK GLD R0069	12	2400	SET of 2

DOUBLE-SIDED SYNCHRONOUS

1778SLV14M60DDS	1778 SLV14 DD 60	60	1778	SET of 2
1778SLV14M75DD	1778 SLV14 DD 75	75	1778	

DOUBLE-SIDED PV

18-1657/2	PV BELT 22 PL DD 1765 18-1657/2	22	1765	
18-9525/2	PV BELT 26 PL DD 1765 18-9525/2	26	1765	

BELT TYPE	TOOTH PITCH (mm)	RIB PITCH (mm)	MAX. BELT WIDTH (mm)	MAX. PITCH LENGTH (mm)	MAX. NUMBER OF RIBS
Synchronous with PV back	8 & 14	3,56 (PVK) & 4,70 (PVL)	500	4400 (8M) & 4956 (14M)	-
Double-sided synchronous	8 & 14	-	250/285	4400 (8M) & 4956 (14M)	-
Double-sided PV	-	3,56 (PVK) & 4,70 (PVL)	500	5000	140/106

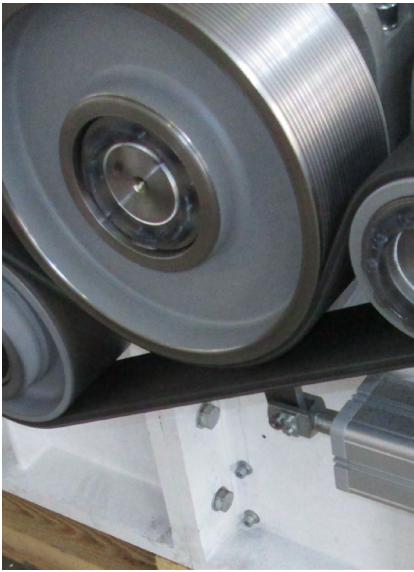

CASE STUDY

APPLICATION: Roller mill

PREVIOUS SOLUTION: Competitor's set of synchronous belts with PV back

PREVIOUS BELT PROBLEMS:

- Tooth jump and requirement for increased power transmission within a limited amount of space

MEGADYNE SOLUTION: DOUBLE-SIDED PV-L

- Megadyne's DOUBLE-SIDED PV-L for a smooth, powerful, and narrow drive



CASE STUDY

APPLICATION: Roller mill

PREVIOUS SOLUTION: Competitor's standard synchronous belt with PV back

PREVIOUS BELT PROBLEMS:

- The high load was causing pulley wear and tooth jumps that damaged the cords and consequently the belts

MEGADYNE SOLUTION: SYNCHRONOUS 8M RPP GOLD PV-L

- Megadyne's synchronous 8M RPP GOLD PV-L, with its high-breaking strength cords



ABOUT SUSTAINABILITY

Sustainability has always been a guiding principle for Ammega and all members of Ammega Group. We are proud to work with **EcoVadis** to monitor and evaluate our environmental, social, and ethical performance. At Megadyne, we are committed to becoming more and more responsible towards the world by reducing our impact on the planet. We work on new technological raw materials made by partners using the most ecological sustainable technologies. Our team has been working on the continuous improvement of products, services, and solutions for the benefit of society and the environment. Our vision is to be the local partner of choice for sustainable belting solutions around the globe.

Important sustainability achievements include improvements throughout the supply chain and in tracking our carbon footprint as well as the launch of new sustainable solutions for our clients. Major steps forward on sustainable investments are slowly bringing us closer to goals set in the Paris Agreement. We are on a journey towards a sustainable future, continually revising our plans and raising the level of our ambitions wherever possible. Our business performance and successes are key factors in defining our impact on the economic, social, and natural environment. We take the responsibility for this impact for all stakeholders and make every endeavour strengthen our roles as conscientious corporate citizens.

CERTIFICATIONS



All Megadyne polyurethane power transmission belts comply with ISO 14001, ISO 9001 and European RoHS Directive. The belts are made with raw materials in compliance with REACH standards, meaning that all belts, pulleys, toothed bars, couplings blocking units and other items supplied by Megadyne do not contain one (or several) of the SVHC in Candidate List above a concentration of 0.1% w/w.

All Megadyne rubber power transmission belts are made in accordance with the Quality Management System Standard: ISO 9001 and ISO 14001. These certificates are valid for the following field of application: design, manufacture and sale of power transmission belts.

Discover Your Local Contacts

The local partner of choice
for sustainable power transmission belting solutions
around the globe.



General contact information:

Megadyne

Via Trieste, 16
Via S. Lucia 114 - 10075 Mathi (Torino)
Italy



Scan the QR code
and find your local
contact

